

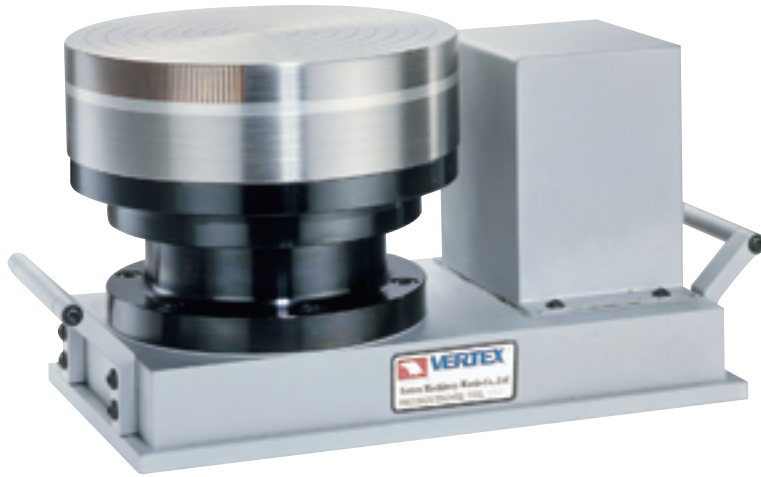

# Variable Speed Rotary Magnetic Chuck



**VOLTS 220V, 50/60HZ  
SINGLE PHASE**

**MAX. LOAD WIGHTS  
VRM-8 IS 18 KGS  
VRM-10 IS 25 KGS**

**ADJ. ROTARY SPEED  
VRM-8 15-150 RPM  
VRM-10 10-100RPM**

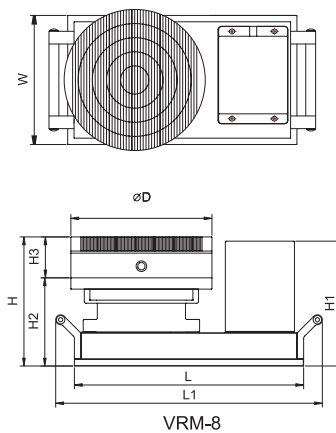
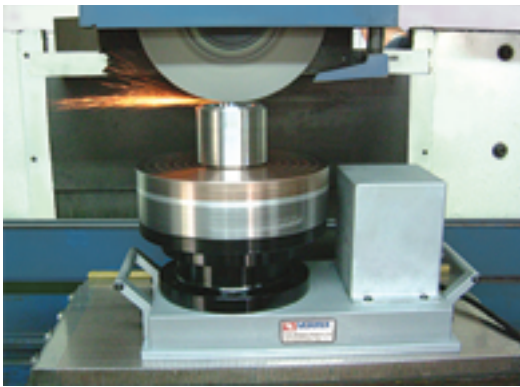

VRM-8

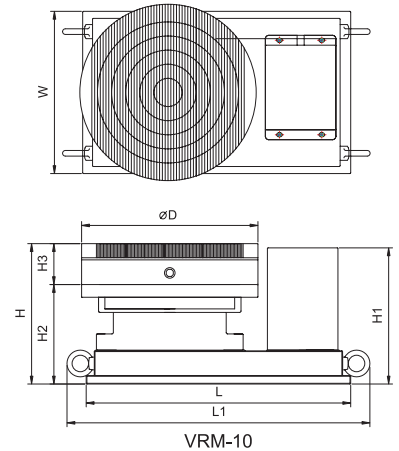

VRM-10

ORDER NO	L	L1	W	H	H1	H2	H3	ØD	VOLT	G.W.	CODE NO.
VRM-8	325	378	183	182	177	124	58	200	220V	57kg	8001-047
VRM-10	376	437	230	200	193	141	58	250	220V	75kg	8001-048

## FEATURE:

1. This rotary magnetic chuck with the motor. The rotary speed can adjustable.
2. It's easy and simple for set up on the surface grinding machine. It's for do rotary grind.
3. The precision is within 0.002 m/m. High precision, High efficient.
4. It provides well prevention for dust, coolant, and lubricants. Spindle end be applied accuracy bearing, can be assured to keep very steady under load grinding.