

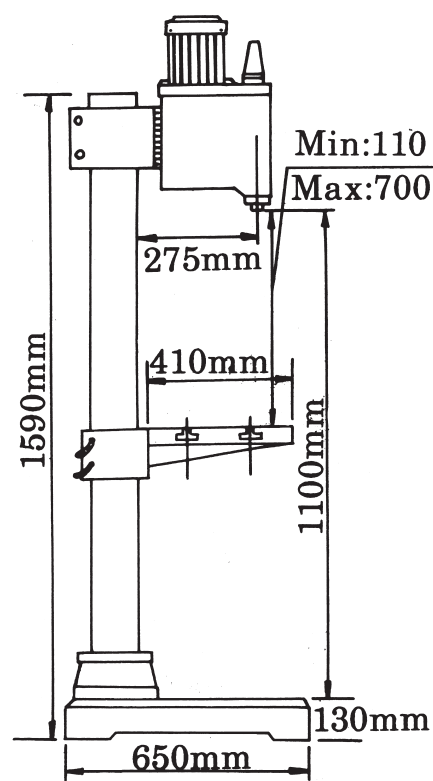

All Geared Head Drill Press

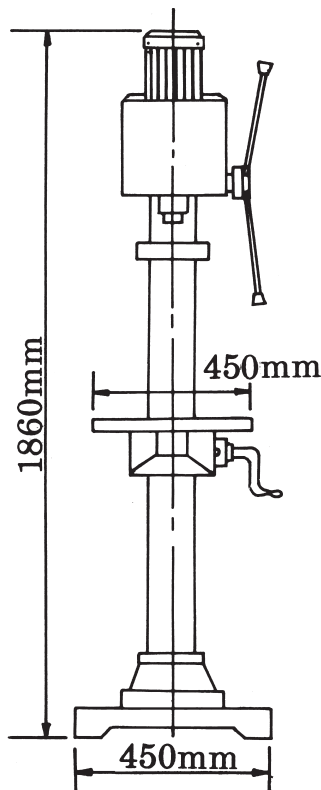

GMB-400GS

| ORDER NO. | CODE NO. |
|-----------|----------|
| GMB-400GS | 8001-063 |

FEATURES

1. Available for drilling, Tapping etc.
2. Gear head can be tilted 90° R & L each.
3. Gear head can be swivelled 360°.
4. Spindle stroke: 120mm
5. Drill capacity: 32mm (steel).
40mm (casting iron).
6. Quickly assembled cabinet stand & chip tray, for GEM-400GD (option).
7. Available CE standard as fig. show.
Electrical control system protecting guard.

SPECIFICATIONS

| ORDER NO. | | GMB-400GS | ACCESSORIES |
|-----------------------|---------|--------------------------------|---|
| DRILL CAPACITY | CASTING | 40mm(1-9/16") | STANDARD ACCESSORIES 1. CHUCK ARBOR 2. TOOL & TOOL BOX 3. FORWARD/REVERSE SWITCH OPTIONAL ACCESSORIES 1. 4" SWIVEL VISE 2. 6" SWIVEL VISE 3. 52PCS CLAMPING KITS (M12) 4. 13mm CHUCK 5. CABINET STAND & CHIP TRAY FOR GEM-400GD 6. TWO SPEEDS MOTOR & SWITCH 2P/4P.3PH 7. CE STANDARD (REQUIREMENT AS FIG SHOWN) 8. TAPPING FUNCTION 9. COOLANT SYSTEM 10. 1.5HP ON REQUEST |
| | STEEL | 32mm(1-1/4") | |
| SPINDLE TAPER | | MT#3 OR R- 8 | |
| SPINDLE NOSE TO BASE | | 1100mm | |
| SPINDLE NOSE TO TABLE | | 700mm | |
| COLUMN DIA. | | ∅115mm | |
| QUILL DIA. | | ∅75mm | |
| QUILL TRAVEL | | 120mm | |
| SWING | | 550mm | |
| HEAD TILTING | | 90°R& L | |
| HEAD SWIVEL | | 360° | |
| MAIN MOTOR | | 0.75PS. 1HP | |
| SPINDLE SPEEDS | 50HZ | 50,100,170,370,1250RPM(4P) | |
| | 60HZ | 60,120,200,450,850,1500RPM(4P) | |
| TABLE SURFACE | | 410x450mm | |
| MACHINE HIGHT | | 1860mm | |
| T-SLOT SIZE | | 14mm | |
| N.W./G.W. | | 290KGS/305KGS | |
| MEASUREMENT | | 740x540x1955m/m | |
| BASE SIZE | | 450x650m/m | |