

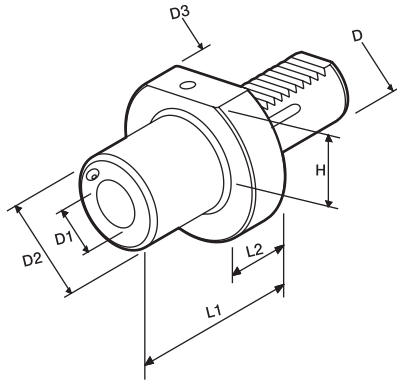

DIN 69880 Stacit Holders

TYPE F



- Tool holders with morse taper according DIN 228
- External coolant supply

DIMENSIONS

Order No.	D	D1	D2	D3	H	L1	L2	CODE NO.
F20-MT1	20	MT1	-	50	-	23	-	5006-343
F30-MT1	30	MT1	52	68	28	27	22	5006-344
F30-MT2	30	MT2	58	68	28	27	22	5006-345
F30-MT3	30	MT3	64	68	28	36	22	5006-346
F40-MT2	40	MT2	55	83	32.5	36	22	5006-347
F40-MT3	40	MT3	58	83	32.5	36	22	5006-348
F40-MT4	40	MT4	68	83	32.5	50	22	5006-349
F50-MT2	50	MT2	55	98	35	36	30	5006-350
F50-MT3	50	MT3	58	98	35	36	30	5006-351
F50-MT4	50	MT4	68	98	35	50	30	5006-352
F60-MT3	60	MT3	58	123	42.5	36	30	5006-353
F60-MT4	60	MT4	68	123	55	36	30	5006-354



DIN 69880 Axial Stacit Holders

TYPE T1

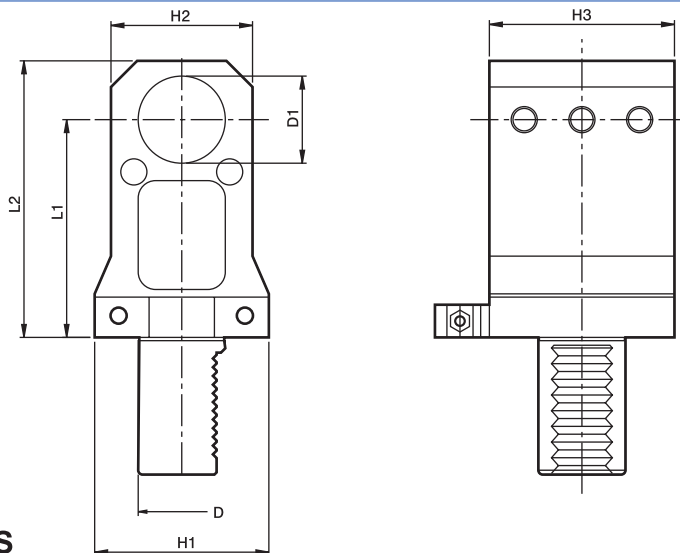

- External, internal coolant supply

DIMENSIONS

Order No.	D	D1	H1	H2	H3	L1	L2	CODE NO.
T1-30-32-65	30	32	65	52	62	65	90	5006-355
T1-30-32-85	30	32	65	52	62	85	108	5006-356
T1-30-32-100	30	32	65	52	62	100	123	5006-357
T1-30-32-120	30	32	65	52	62	120	143	5006-358
T1-40-32-85	40	32	80	65	85	85	112	5006-359
T1-40-40-85	40	40	80	65	85	85	112	5006-360
T1-40-40-100	40	40	80	65	85	100	127	5006-361