

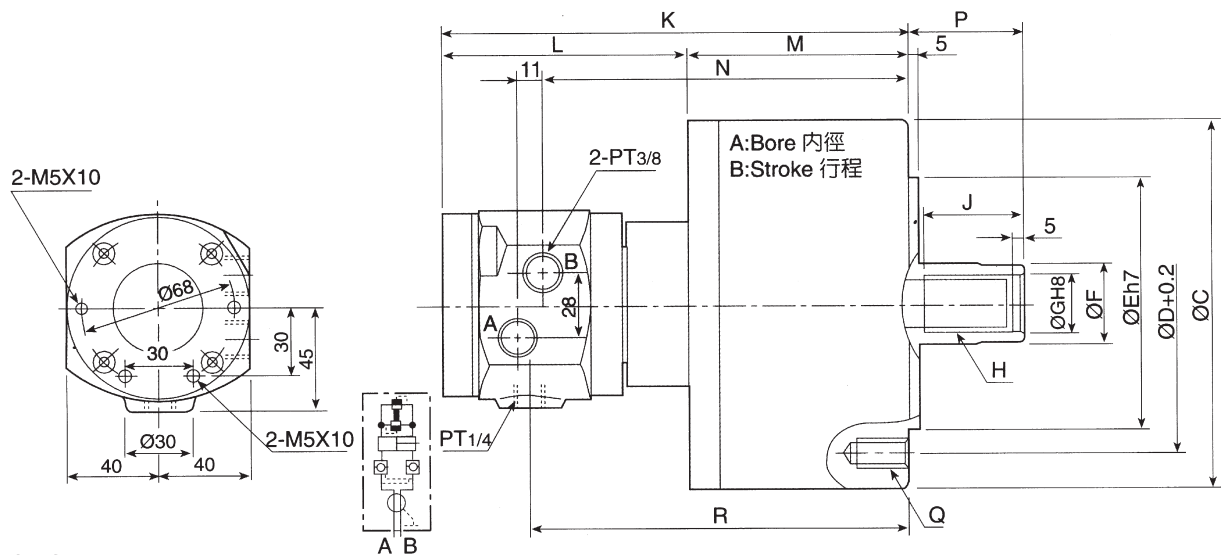

Non Through Hole Rotary Hydraulic Cylinder (With Valves)



1. Built-in safety check valves.



DIMENSIONS

ORDER NO.	DIM	A	B	C	D	E	F	G	H	J	K	L	M	N	P Max.	P Min.	Q	R	CODE NO.
		MS105	105	20	135	100	80	30	21	M20x2.5	35	197	108	89	152	45	25	6-M10x20	158
MS125	125	25	160	130	110	35	25	M24x3.0	44	205	108	97	160	51	26	6-M12x24	166	5003-031	
MS150	150	30	190	130	110	45	31	M30x3.5	45	214	108	106	169	56	26	12-M12x24	175	5003-032	
MS200	200	35	245	145	120	55	37	M36x4.0	60	228	108	122	183	69	34	12-M16x30	189	5003-033	

SPECIFICATIONS

ORDER NO.	DIM	Piston Area		Max. Draw Bar Pull Pull Side KN(kgf)	Piston Stroke (mm)	Max. Speed (r.p.m.)	Max. Operating Pressure (kgf/cm ²)	Total Leakage (l/min)	Moment Inertia I (kg.h.m ²)	Weight (kg)
		Push Side (cm ²)	Pull Side (cm ²)							
MS105		86	79	29(2957)	20	6000	4.0(40.8)	0.8	0.0125	7.1
MS125		122	113	42(4283)	25	6000	4.0(40.8)	0.8	0.0225	10
MS150		176	160	60(6118)	30	5500	4.0(40.8)	0.8	0.0475	13.5
MS200		314	290	108(11013)	35	5500	4.0(40.8)	0.8	0.0975	22