

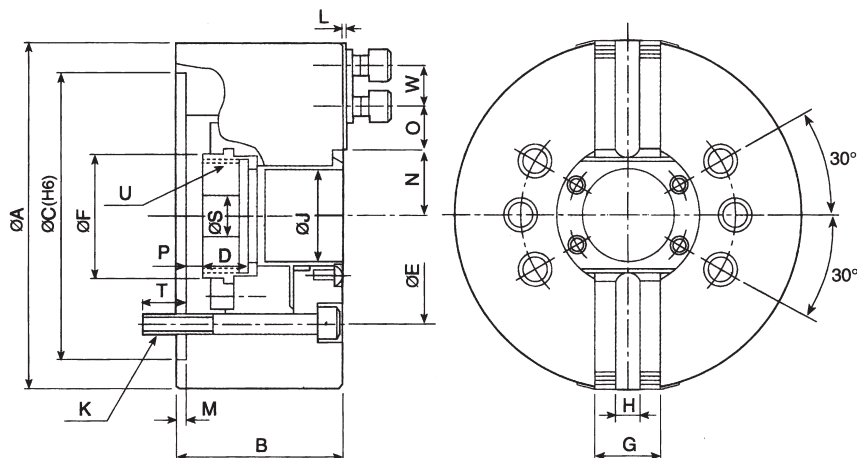

2-Jaw wedge Type Through-hole Power Chuck(Without Adaptor)



1. All sliding surfaces are hardened and ground for accurate actual running and long service repeatability. Lubrication nipple in each base jaw.
2. Base jaw:
1.5mmx60o serrtion.
3. Mounting:
Adaptor mounting to fit with DIN,ISO,BS,ASA B5.9 type A spindles.

SPECIFICATIONS

Unit:mm

Dim	ORDER NO.	NT205	NT206	NT208	NT210	NT212	NT215
Through-Hole(mm)		∅33	∅45	∅52	∅75	∅91	∅117.5
Plunger Stroke(mm)		10	12	16	19	23	23
Jaw Stroke(mm)		5.4	5.5	7.4	8.8	10.6	10.6
Max.Draw Bar Pull Force(kgf)		1189	1479	2294	2906	3739	4793
Max.Gripping Force(kgf)		2447	3875	5710	7546	9789	12236
Max.Speed(r.p.m.)		7000	6000	4800	4200	3300	2500
Weight(kg)		5.9	13	22.1	33.2	61.9	115
Matching Cylinder		M1036	M1246	M1552	M1875	M2091	M2511
Max.Operating Pressure(kgt/cm ²)		19.5	18.9	17.3	18.4	18.4	15.3
Matching Soft Jaw		HC05	HC06	HC08	HC10	HC12	HC15
Matching Hard Jaw		HJ05	HJ06	HJ08	HJ10	HJ12	HJ15
CODE NO.		5002-250	5002-251	5002-252	5002-253	5002-254	5002-255

DIMENSIONS

Unit:mm

Dim	ORDER NO.	NT205	NT206	NT208	NT210	NT212	NT215
A		135	169	210	254	304	381
B		60	81	91	100	110	133
C(H6)		110	140	170	220	220	300
D		20	19	20.5	25	28	43
E		82.55	104.78	133.35	171.45	171.45	235
M		4	5	5	5	6	6
G		23	32	37	42	52	62
H		10	12	14	16	21	24
J		33	45	52	75	91	117.5
K		3-M10	6-M10	6-M12	6-M16	6-M16	6-M20
L		2	2	2	2	2	5
F		45	60	66	94	108	139
N max.		26.5	32	38.7	51	61.3	82
N min.		23.8	29.25	35	46.6	56	76.7
O max.		19.75	22.75	29.75	33.75	45.75	46.75
O min.		7.75	9.25	14.75	14.25	15.75	13.75
P max.		1	11	14.5	8.5	8	7
P min.		-9	-1	-1.5	-10.5	-15	-16
S		12	20	30	45	50	60
T		15.5	16	20	22	23	30
U max.		M40x1.5	M55x2	M60x2	M85x2	M100x2	M130x2
W		14	20	25	30	30	43