

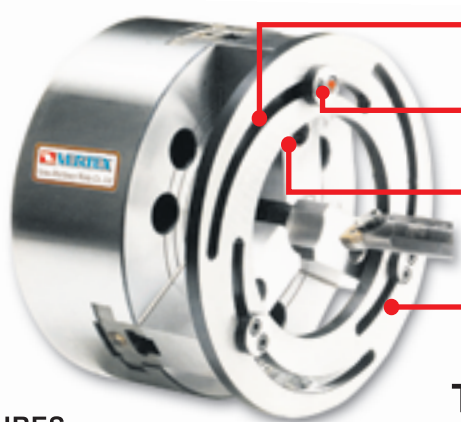

# Soft Jaw Forming Ring



- The size can be adjusted against the helical slot.
- Bias pin can be rotated 180 degree for different size to extend a clamping range.
- Don't need to drill new hole. The hole on the soft jaws can be used directly for bias pin.
- The material, which is hardened and ground, can last for a long time.

## THE CHUCK NOT INCLUDING

### FAETURES

- Forming ring is available for 5", 6", 8", 10" & 12" power chuck.
- The clamping force is increasing. the roundness and vibration caused by eccentricity can be improved. The cutting accuracy is much better because of no taper hole (as fig.3) and less vibration.
- Both Clamping (as fig.1) and extension (as fig.2) are available. Meanwhile, the size adjusting is at will, the operation is easy and endurable.
- More improvement for used chuck to have high accuracy & strong clamping force .

### INSTRUCTION

Because the forming ring is used for cutting forming soft jaw by clamping. extending through-hole. therefore increasing the accuracy of clamping workpiece. (please refer to fig.1,2&3)

As fig.4 the soft jaw is made without forming ring. So that the cone is made. and bad round-out. more vibration and less clamping force emerge.

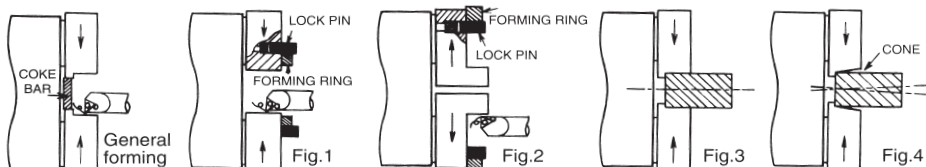

ORDER NO.	SUIT TO SK-CHUCK SIZE	CODE NO
VFR-05	5"	5002-360
VFR-06	6"	5002-361
VFR-08	8"	5002-362
VFR-10	10"	5002-363
VFR-12	12"	5002-364



# Hard Jaws For Hydraulic Power Chucks

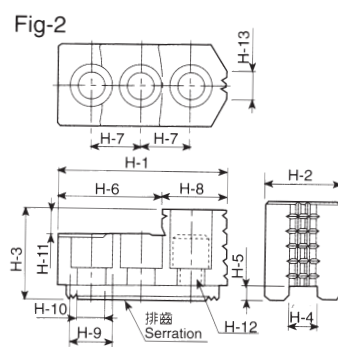
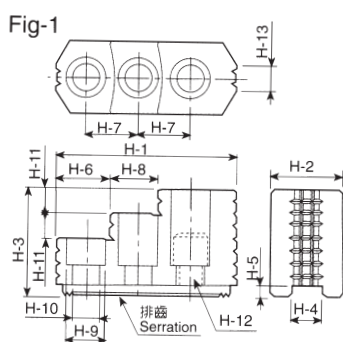

1. Hard jaw for hydraulic power chucks. 2. Hard jaw for CNC lathe.

### DIMENSIONS

Unit:mm

ORDER NO.	Dim													Serration Pitch	Matching Chuck	3Jaw Weight(kg)	CODE NO	
	H-1	H-2	H-3	H-4	H-5	H-6	H-7	H-8	H-9	H-10	H-11	H-12	H-13					
HJ05	53	23	27.5	10	4	30.5	14	22.5	13.5	8.5	10	M8	6	1.5x60°	Fig-2	N-205	0.4	5002-401
HJ06	67.5	31	35	12	5	13	20	46	17	11	12	M10	16	1.5x60°	Fig-2	N-206.V-206	1.0	5002-402
HJ08	86	35	51	14	5	31	25	18	19	13	12	M12	12	1.5x60°	Fig-1	N-208.V-208	1.9	5002-403
HJ10	99.5	40	54	16	5	43	30	17	19	13	13	M12	15	1.5x60°	Fig-1	N-210.V-210	2.9	5002-404
HJ12	103	50	52	21	4	62.5	30	40.5	25	17	17	M16	30	1.5x60°	Fig-2	N-212	2.65	5002-405
HJ12-1	103	50	52	18	5	62.5	30	40.5	22	15	17	M14	30	1.5x60°	Fig-2	V-212	2.7	5002-406
HJ15	149	62	86	22	8	63	43	34	32	21	20	M20	40	1.5x60°	Fig-1	N-215	9.6	5002-407
HJ15-1	149	62	86	25.5	5	63	43	34	32	21	20	M20	40	1.5x60°	Fig-1	V-215	9.5	5002-408