

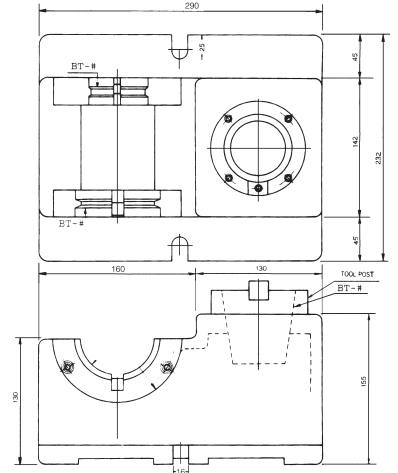

Deluxe Type Tool Setting Stand



- (A) This tool setting stand is one kind of subsidize tool for helping machine center to work efficiently. To be used fixing the tools on tool holder. It could avoid the method of using draw bar to fix (on machine center). It is both safety and don't effect the precision of machine's spindle.
- (B) It could selet using on horizontal or vertical lines, simple & quick operations.
- (C) A multi-function tool, it is changeable, has two kinds of specifications can be used. That is to say, one machine could be used as two sets machines.
- (D) Additional special accessories to make your operating more convenient.

ORDER NO.	SHANK TAPERS		WEIGHT (kg)	CODE NO.
	TOOL POST	ADAPTER HOLDING		
VTD-1	BT-#40x1	BT-#40x2	25	3405-001
VTD-2	BT-#50x1	BT-#50x2	23	3405-002
VTD-3	BT-#50x1	BT-#50x1 BT-#40x1	24	3405-003
VTD-4	BT-#40x1	BT-#50x1 BT-#40x1	24	3405-004



Simple Type Tool Setting Stand



- A. This tool setting stand is one kind of subsidize tool for helping machine center to work efficiently. To be used fixing the tools on tool holder. It could avoid the method of using draw bar to fix (on machine center). It is both safety and don't effect the precision of machine's spindle.
- B. It is simple structive type. And could fix tooling on the above and hold the pull studs on the below of it. This is the excellent helping tools for simple, rapid and safety.

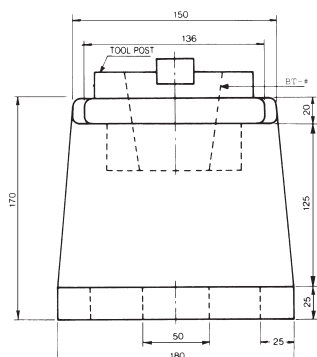

ORDER NO.	SHANK TAPERS	STD	WEIGHT	CODE NO.
VTS-BT-30	30	BT	13kg	3405-010
VTS-BT-40	40	ISO	13kg	3405-011
VTS-BT-50	50	NT	12kg	3405-012
VTS-SK-30	30	DIN 69871A	13kg	3405-013
VTS-SK-40	40		13kg	3405-014
VTS-SK-50	50		12kg	3405-015

