



Quick Change Tapping Chucks

QUICK CHANGE TAP COLLETS (with overload clutch)

1PC≐0.18kg

Size	Thread	Tap Shank		∅D ₁	L ₁	L ₂	ORDER NO.	CODE NO.
		∅D	□					
TC312 (#1)	M3	4	3.2	19	21.5	25	312-01	3404-200
	M4	5	4				312-02	3404-201
	M5	5.5	4.5				312-03	3404-202
	M6	6	4.5				312-04	3404-203
	M7	6.2	5				312-05	3404-204
	M8	6.2	5				312-06	3404-205
	M9	7	5.5				312-07	3404-206
	M10	7	5.5				312-08	3404-207
	M11	8	6				312-09	3404-208
	M12	8.5	6.5				312-10	3404-209
	•M14	10.5	8				•312-11	3404-210
	•M15	10.5	8				•312-12	3404-211
	UNC 1/4	6	4.5				312-13	3404-212
	UNC 5/16	6.1	5				312-14	3404-213
	UNC 3/8	7	5.5				312-15	3404-214
	UNC 7/16	8	6				312-16	3404-215
	UNC 1/2	9	7				312-17	3404-216
	•UNC 9/16	10.5	8				•312-18	3404-217
	PT 1/8	8	6				312-19	3404-218
	PT 1/4	11	9				312-20	3404-219

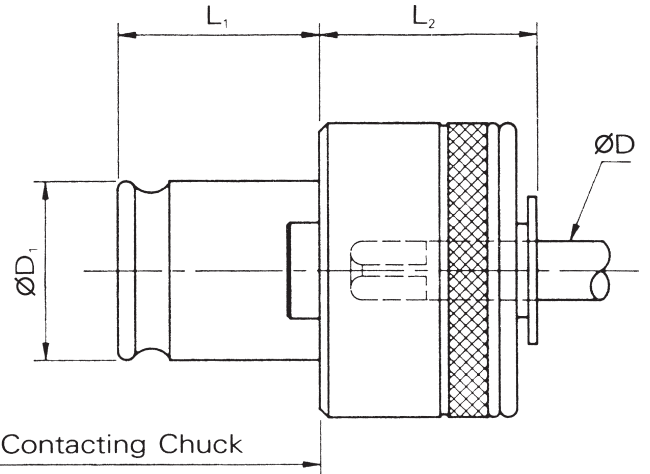

- Torque is factory-set to protect the tap for which a particular collet is designed. Small adjustments can be made by a trained user to accommodate tap strength and material variations.
- Collet stops driving when set torque is exceeded.
- A collet is necessary for each tap shank diameter.
- DIN & ISO systems : please see page 68.

1PC≐1.8kg

1PC≐0.6kg

Size	Thread	Tap Shank		∅D ₁	L ₁	L ₂	ORDER NO.	CODE NO.
		∅D	□					
TC820 (#2)	M7	6.2	5	31	35	34	820-01	3404-230
	M8	6.2	5				820-02	3404-231
	M9	7	5.5				820-03	3404-232
	M10	7	5.5				820-04	3404-233
	M11	8	6				820-05	3404-234
	M12	8.5	6.5				820-06	3404-235
	M14	10.5	8				820-07	3404-236
	M15	10.5	8				820-08	3404-237
	M16	12.5	10				820-09	3404-238
	M17	13	10				820-10	3404-239
	M18	14	11				820-11	3404-240
	M20	15	12				820-12	3404-241
	M22	17	13				820-13	3404-242
	UNC 3/8	7	5.5				820-14	3404-243
	UNC 7/16	8	6				820-15	3404-244
	UNC 1/2	9	7				820-16	3404-245
	UNC 9/16	10.5	8				820-17	3404-246
	UNC 5/8	12	9				820-18	3404-247
	UNC 3/4	14	11				820-19	3404-248
	UNC 7/8	17	13				820-20	3404-249
	PT 1/8	8	6				820-21	3404-250
	PT 1/4	11	9				820-22	3404-251
	PT 3/8	14	11				820-23	3404-252
	PT 1/2	18	14				820-24	3404-253

Size	Thread	Tap Shank		∅D ₁	L ₁	L ₂	ORDER NO.	CODE NO.
		∅D	□					
TC1433 (#3)	M14	10.5	8	48	55.5	45	1433-01	3404-260
	M15	10.5	8				1433-02	3404-261
	M16	12.5	10				1433-03	3404-262
	M17	13	10				1433-04	3404-263
	M18	14	11				1433-05	3404-264
	M20	15	12				1433-06	3404-265
	M22	17	13				1433-07	3404-266
	M24	19	15				1433-08	3404-267
	M25	19	15				1433-09	3404-268
	M26	20	15				1433-10	3404-269
	M27	20	15				1433-11	3404-270
	M28	21	17				1433-12	3404-271
	M30	23	17				1433-13	3404-272
	M32	24	19				1433-14	3404-273
	M33	25	19				1433-15	3404-274
	M34	26	21				1433-16	3404-275
	M35	26	21				1433-17	3404-276
	M36	28	21				1433-18	3404-277
	UNC 9/16	10.5	8				1433-19	3404-278
	UNC 5/8	12	9				1433-20	3404-279
	UNC 3/4	14	11				1433-21	3404-280
	UNC 7/8	17	13				1433-22	3404-281
	UNC 1	20	15				1433-23	3404-282
	UNC 1 1/8	22	17				1433-24	3404-283
	UNC 1 1/4	24	19				1433-25	3404-284
	UNC 1 3/8	26	21				1433-26	3404-285
	PT 1/4	11	9				1433-27	3404-286
	PT 3/8	14	11				1433-28	3404-287
	PT 1/2	18	14				1433-29	3404-288
	PT 3/4	23	17				1433-30	3404-289
	PT 1	26	21				1433-31	3404-290