

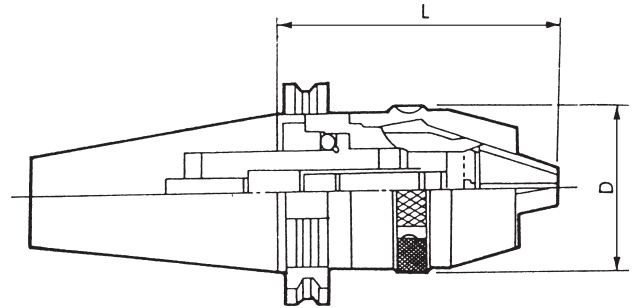

Drill Chuck Holder / APU DIN 69871A

DIN69871 A



Unit:mm

ORDER NO.	SIZE	Clamping range (\varnothing mm)	D	L		WEIGHT (kg)	CODE NO.
				Minimum	Maximum		
SK-511	SK40-APU08-80	1-8	36.3	80	86.5	1.3	3301-001
SK-512	SK40-APU13-105	1-13	51.5	105	109	1.7	3301-002
SK-513	SK50-APU08-80	1-8	36.3	80	97.5	3.8	3301-003
SK-514	SK50-APU13-105	1-13	51.5	105	120	4.1	3301-004
SK-509	SK30-APU08-70	0.5-8	36				3301-005
SK-510	SK30-APU13-82	0.5-13	50				3301-006



Drill Chuck Holder

DIN 69871A

DIN69871 A

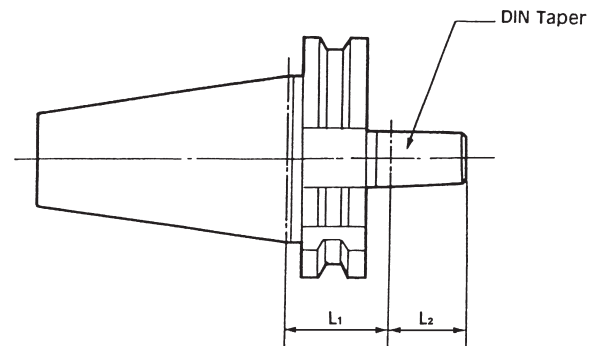

Unit:mm

ORDER NO.	SIZE	DIN Tper #	L1	L2	WEIGHT (kg)	CODE NO.
SK-521	SK40-B16	B16	45	24	0.7	3209-180
SK-522	SK40-B18	B18	32	32	1	3209-181
SK-523	SK50-B16	B16	45	24	2.5	3209-182
SK-524	SK50-B18	B18	43	32	3	3209-183