

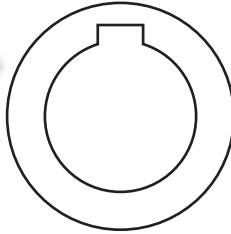

Slotting Head Unit



ORDER NO.	CODE NO.
VSH-R8	1012-001
VSH-NT30	1012-002
VSH-NT40	1012-003



This device's maximum up-and-down travel is 50mm. It can be mounted on general milling machine as Slotting Head.

1. IT IS QUICK AND HANDY FOR CHANGING THE TOOLS
2. PROCESS FUNCTION:RIGHT ANGLE.
3. IT'S SUITABLE FOR ALL THE MACHINE TOOLS (EXAMPLE: VERTICAL TURRET MILLING MACHINE, BORING MACHINE, MACHINING CENTER,ETC.)

ORDER NO.	VSH-
SPINDLE TAPER	R8 , NT30 , NT40
TRAVEL	50mm
CUTTER	4mm, 5mm
WEIGHT	9KGS
L x B x H	240x250x150mm



Precision Slotting Head

ORDER NO. VSH-125 CODE NO. 1012-010

Features

- 1.Special design worm and worm gear with linkage transmission mechanism, well construction and highly power output.
- 2.The ram-sliding surface are hardened and precision ground
- 3.Built in lubricating system for smoothly running and prolong the life of head
- 4.Available mounting on any type milling m/c back side of the ram.

Specification

Stroke:125mm(5")

No. of stroke speed change:5 steps

Stroke speed (stroke/min):30,47,69,98,140 spm(50HZ)

Stroke speed (stroke/min):35,54,79,112,160 spm(60HZ)

Driving Motor:3/4HP-6P

G.WEIGHT: 150kgs

Optional Accessories

1. Flange A
2. Flange B
3. Slotting bar & cutter
4, 5, 6, 7, 8, 10mm

ORDER NO.	CUTTER & DESCRIPTION	WEIGHT (kg)	CODE NO.
VSH-4C	Slotting bar 4mm	0.07	1012-011
VSH-5C	Slotting bar 5mm	0.08	1012-012
VSH-6C	Slotting bar 6mm	0.09	1012-013
VSH-7C	Slotting bar 7mm	0.1	1012-014
VSH-8C	Slotting bar 8mm	0.1	1012-015
VSH-10C	Slotting bar 10mm	0.1	1012-016
VSH-FGA	FLANGE A	17	1012-017
VSH-FGB	FLANGE B	22	1012-018



1.Direct mounting

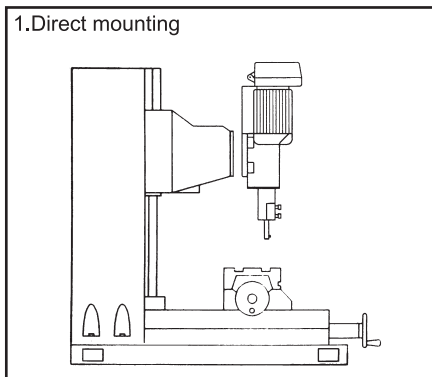

2.Mounting with flange A

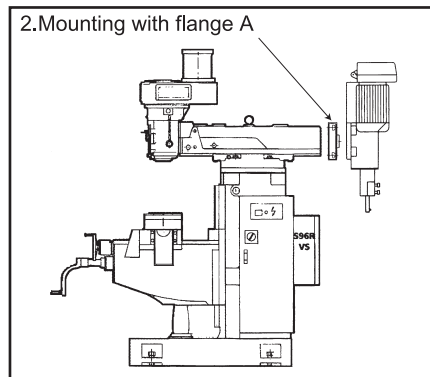

3.Mounting with flange B

