



# Precision Cross Table



VCT-407



VCT-514

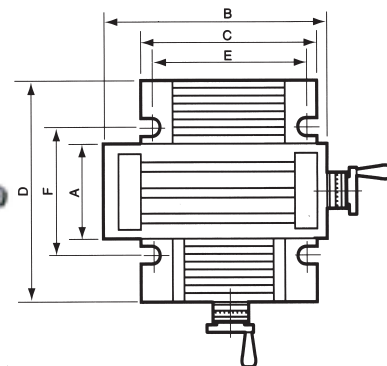

- Material:over FC-30
- Precision:0.02/100mm
- Feature:The sliding surfaces are treated by heat-treatment & precision ground

## Specifications

Unit:mm

ORDER NO.	A	B	C	D	E	F	Stroke	T Slot	Total height	Dial graduation	PACKING LxWxH m/m	WEIGHT kgs	CODE NO.
VCT-407	100	185	130	100	115	50	50x80	3/8"	100	2mm/0.01	290x240x140	16	1007-001
VCT-514	150	350	250	300	220	205	150x175	3/8"	130	4mm/0.02	510x450x240	38	1007-002
VCT-820	200	500	300	400	250	290	200x250	3/8"	160	4mm/0.02	670x560x280	78	1007-003
VCT-1024	250	600	400	500	340	430	250x300	1/2"	210	4mm/0.02	790x680x310	141	1007-004



# Precision Cross Table



VCT-830

A heavy, rugged slide in all kinds of positioning, milling, drilling micro-scope viewing and staging, adjustable bases for heavy loads, small jig boring, precision cut-off.

(m/m)

ORDER NO.	VCT-830
TABLE:	210X730MM
HEIGHT:	150MM
TRAVEL:	350X165MM
BASE:	360X285MM
DIAL GRADUATED	0.02MM
NET WEIGHT	85KGS
CODE NO.	1007-010



# Cross Table

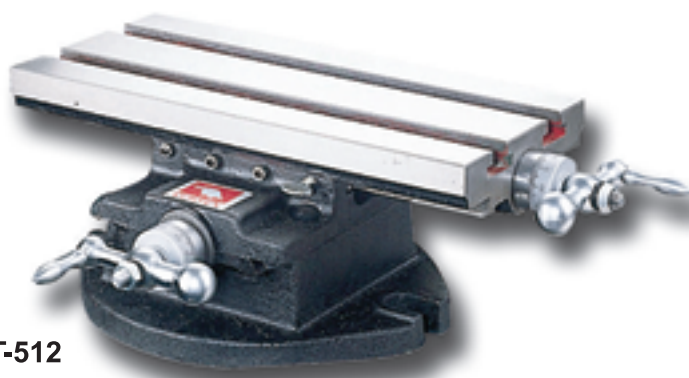

VCT-512

## ORDER NO. VCT-512 CODE NO. 1007-020

Table:300x140mm  
 Height:115mm  
 Travel:200mm longitudinal.  
 125mm transverse.  
 Base:225mmx200mm oval with U slots for up to 16 bolts on 190 to 210 bolts circle.  
 Dial Graduated:0.03mm  
 Net weight:16.6kgs.  
 Packing Volume of each unit:430X265X155mm  
 LIGHT DUTY ONLY