



U/N Work Stopper



NON TEETH TYPE
ORDER NO. VWS-123
CODE NO. 1002-105
WEIGHT: 1kg



ORDER NO. VWS-125
CODE NO. 1002-106
WEIGHT: 1kg

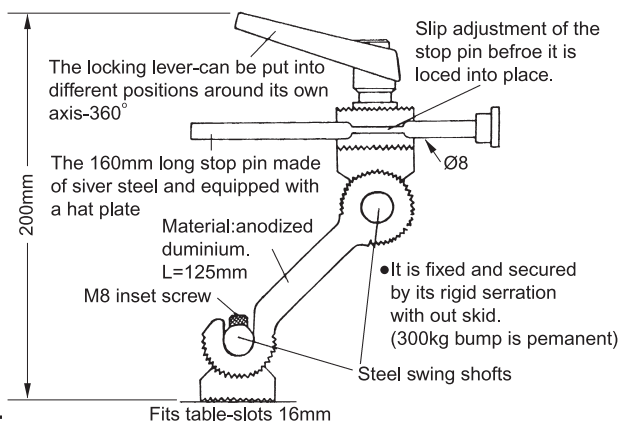

Prisma Jaw

PRISMA JAW



ORDER NO.

VWS-VK-4.5.6.8 VWS-VW-3.4.5
VWS-VA-4.5.6.8 VWS-VMC-4.6
VWS-VH-4.5.6.8 VWS-VQS-3, 4, 5
VWS-VJ-400.500.600

ORDER NO.	WEIGHT	CODE NO.
VWS-VK-4	0.22kg	1002-110
VWS-VK-5	0.31kg	1002-111
VWS-VK-6	0.41kg	1002-112
VWS-VK-8	1.2kg	1002-113

ORDER NO.	WEIGHT	CODE NO.
VWS-VW-3	0.21kg	1002-120
VWS-VW-4	0.31kg	1002-121
VWS-VW-5	4.1kg	1002-122

ORDER NO.	WEIGHT	CODE NO.
VWS-VA-4	0.4kg	1002-130
VWS-VA-5	0.51kg	1002-131
VWS-VA-6	0.96kg	1002-132
VWS-VA-8	1.76kg	1002-133

ORDER NO.	WEIGHT	CODE NO.
VWS-VMC-4	4.1kg	1002-140
VWS-VMC-6	0.96kg	1002-141

ORDER NO.	WEIGHT	CODE NO.
VWS-VJ-400	0.3kg	1002-163
VWS-VJ-500	0.51kg	1002-164
VWS-VJ-600	0.94kg	1002-165

ORDER NO.	WEIGHT	CODE NO.
VWS-VH-4	0.41kg	1002-150
VWS-VH-5	0.71kg	1002-151
VWS-VH-6	0.91kg	1002-152
VWS-VH-8	1.81kg	1002-153

ORDER NO.	CODE NO.
VWS-VQS-3	1002-160
VWS-VQS-4	1002-161
VWS-VQS-5	1002-162



Universal Vise Jaws With Work Stopper



ORDER NO. VWSJ-4.5.6.8

1. Can be fixed on any vise jaw by the two screws on the side.
2. One jaw in multiple-function features.
3. V-type jaw can fix workpiece at horizontal and vertical position.
4. Can be performed as work stopper.



ORDER NO.I.D. Chart:

VWSJ-□—— VISE JAW SIZE (Unit:inch)
└—— SYSTEM NO.

ORDER NO.	WEIGHT	CODE NO.
VWSJ-4	1.5kg	1002-170
VWSJ-5	1.7kg	1002-171
VWSJ-6	2kg	1002-172
VWSJ-8	4kg	1002-173