



Universal Tilting Rotary Table

NEW



- Tilting range 0-90 degrees from horizontal to vertical position, It is high rigidity.
- Minimum Set-up time has two screws to lock setting. Low profile body for bigger capability.
- Worm is hardened and ground. The ratio is 90:1. The work table is graduated a full 360° so that of the handle moves the table through 4°. Micro collar is graduated in steps of 2' min.
- The tailstock & Dividing plates are optional. The sizes is same as the rotary table, please see page A2.
- For arc or index cutting at milling machine, Grinding machine or drill Machine.....

OPTIONAL: 1.TAILSTOCK

ORDER NO.	TS-1
CODE NO.	1001-022



2.DIVIDING PLATE: DP-1

ORDER NO.	CODE NO.
*DP-1 for VU-100, 150	1001-030
*DP-2 for VU-200	1001-031

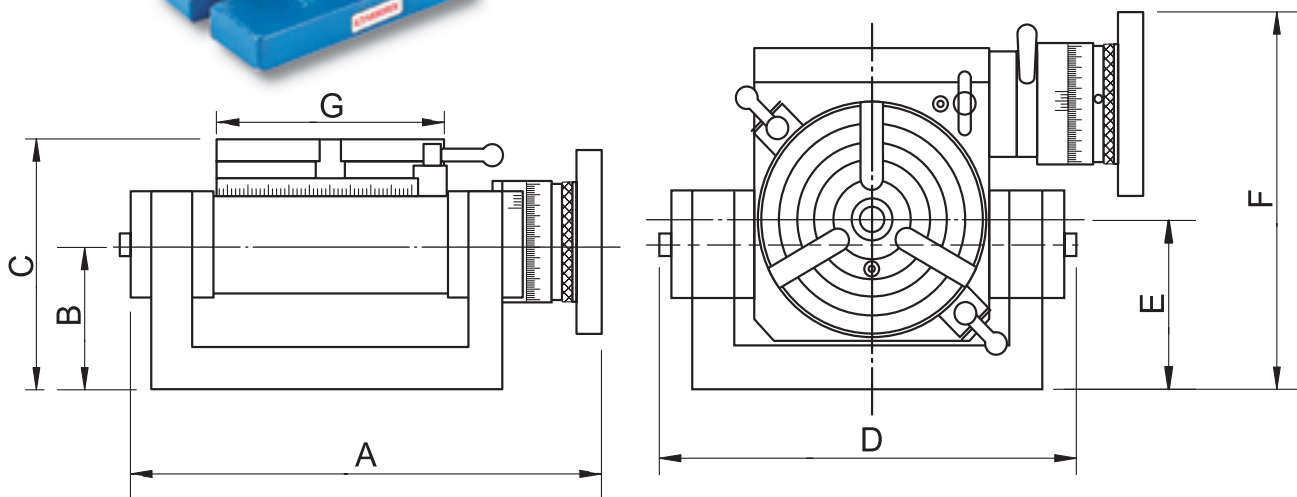

ORDER NO.	A	B	C	D	E	F	G	SUITFUL TAILSTOCK	SUITFUL DIVIDING PLATE	WEIGHT kgs/cuft	CODE NO.
VU-100	228	68	117	202	80	177	100	TS-1	DP-1	13.5kgs/1.5	1001-011
VU-150	266	75	140	246	90	216	150	TS-1	DP-1	21kgs/2.0	1001-012
VU-200	322	85	165	294	100	276	200	TS-2	DP-2	50kgs/2.5	1001-013