



Precision Index Table



2 PCS hirth coupling

ORDER NO.	VIT-300-15	VIT-450-1	VIT-600-1	VIT-700-1	VIT-800-1	VIT-1000-1	VIT-1200-1	
		VIT-450-5	VIT-600-5	VIT-700-5	VIT-800-5	VIT-1000-5	VIT-1200-5	
Table size LxW(mm)	300x300	450x450	600x600	700x700	800x800	1000x1000	1200x1200	
Height(mm)	140	170	200	220	280	300	340	
Spindle hole(mm)	-	ø30	ø40	ø40	ø60	ø60	ø80	
T-slot(mm)	14	18	20	20	22	22	22	
Table rotating		Clockwise and counterclockwise						
Table Lifting up & Clamp down stroke(mm)	5	5	5	5	5	8	8	
Driving	Longitudinal	Manual						
	Revolving	Air Pressure 5~8kgs/cm ²						
Number of division(degree)	15°	1° or 5°						
Division(sec.)		±2						
Max.load weight in theory(kgs)	1200	2400	3400	3400	4500	6000	7000	
Allowable load weight(kgs)	500	1000	2000	2000	3000	5000	6000	
Clamping capacity(kgs)	-	2200	3200	3200	5400	5400	8100	
N.W.(kgs)	90	200	400	600	900	1200	2000	
CODE NO.	1°	1001-070(15)	1001-071	1001-072	1001-073	1001-074	1001-075	1001-076
CODE NO.	5°		1001-081	1001-082	1001-083	1001-084	1001-085	1001-086

- 1.The body is FC-35 cast iron, durable and will last longer without deformation.
- 2.Clamping/Unclamping by pneumatic, easy operation.
- 3.Powerful clamping design, allow heavy cutting and boring.

- 4.Build-in 2 pieces hirth coupling for positioning, indexing accuracy +/-3 sec, ensure a long-term operation.
- 5.Suitable for the high accuracy machining such as Boring-Milling, Grinding-Machine.

DIMENSION

VIT-300

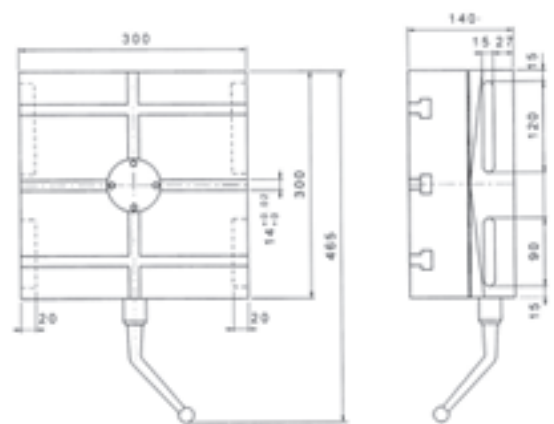
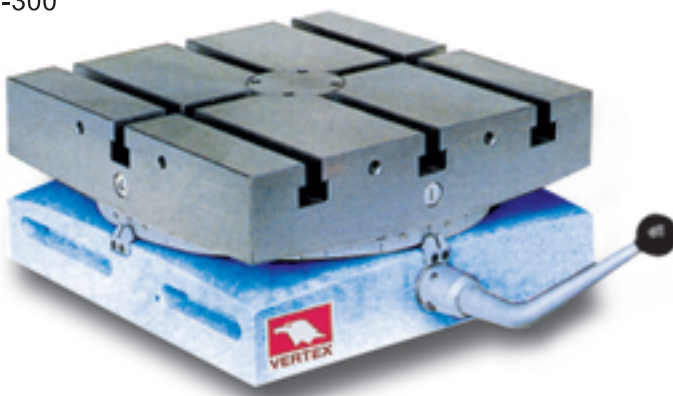

VIT-450~1200

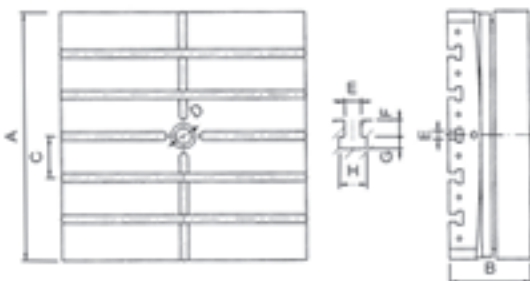

	VIT-450	VIT-600	VIT-700	VIT-800	VIT-1000	VIT-1200
A	450	600	700	800	1000	1200
B	170	200	220	280	300	340
C	100	100	125	100	150	200
D	30	40	40	60	60	80
E	18	20	20	22	22	22
F	16	20	20	23	23	23
G	12	14	14	15	15	15
H	28	35	35	38	38	38